



PRIMA LX 4028.S SR

Perfect balance of
Economy & Turnaround Time



Engine
High performance 267 HP
CRDi engine by Cummins



Gearbox
Proven Tata G1150
9-speed gearbox



Rear Axle
Heavy duty RA 110 axle ideal for
high performance highway applications



Cabin
World class Prima LX cabin
with best-in-class driving comfort

PRIMA LX 4028.S SR

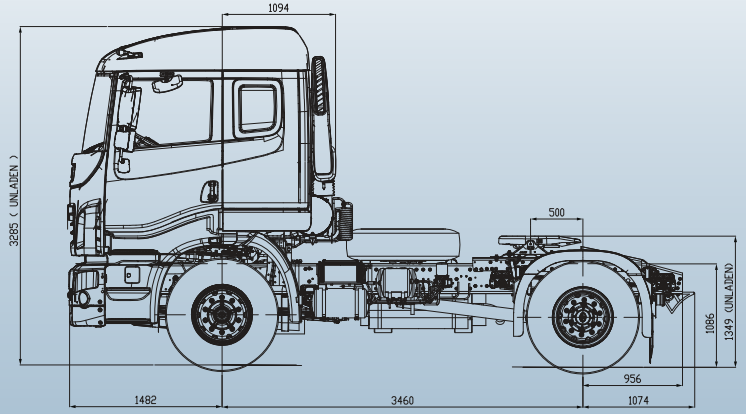
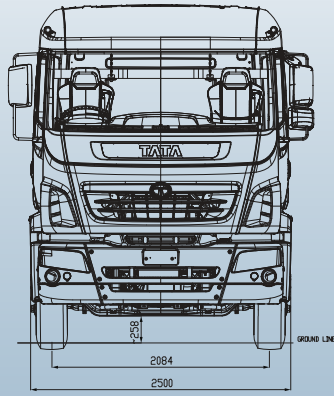

All dimensions in mm

Dimensions (mm)

Overall Width	2585
Overall Length	5898
Wheelbase	3460
Front Overhang	1482
Turning Circle Diameter	12900

Weight (kg)

Unladen Weight	6790
Max. GCW	40200
Max. FAW	6000
Max. RAW	10200

Gearbox & Clutch

Model	G1150 OD 9-speed Synchromesh on all forward speeds; Constant mesh on reverse
Speed	8F + 1Cr + 1R
Gear Ratios	Crawler - 9.37 1st - 6.654, 2nd - 4.897 3rd - 3.571, 4th - 2.69 5th - 1.863, 6th - 1.370 7th - 1.0, 8th - 0.75, Rev - 9.757
Clutch Type	Single Disc, Dry Friction Type
Clutch Dia	430 mm Push Type Area - 1984 sq cm

Rear Drive Axle

Type	Tata RA 110 RR
Axle Ratio	5.86

Chassis & Suspension

Size	286 mm x 90 mm x 7 mm
Type	Fully reinforced
Front Suspension	Parabolic Leaf 90 mm width
Rear Suspension	Semi-elliptical Multi Leaf Spring 90 mm width

Brake

Type	Full Air S-Cam Dual Circuit with ABS
------	--------------------------------------

Engine

Model	Cummins ISBe 270 BSIII
Type	Water-cooled Direct Injection Turbo-charged, After-cooled Diesel Engine; 6 Inline
Other Details	Bore / Stroke: 107 mm x 124 mm Firing Order: 1-5-3-6-2-4 Air Filter: Dry type remote mounted Oil Filter: Full flow spin on paper type Fuel Filter: Pre and fine filtration with water separator
Volume	6700 cc
Power	267 HP @ 2500 rpm
Torque	970 Nm @ 1200-1700 rpm
FIP	HPCR

Cabin and Steering System

Type	Fully Floating Sleeper Cabin Hydraulic Tilt Type
Steering	Tilt & Telescopic Adjustable Steering Wheel Diameter - 470 mm Integral Hydraulic Power-assisted Ratio: 24.2
Instrument Cluster	Digital
AC	Optional

Tyres

Tyres	10R20-16PR/10x20 optional
-------	---------------------------

Fuel Tank

Fuel Tank (liters)	400
--------------------	-----

Performance

Max. Geared Speed in Top Gear (kmph)	100 kmph
Max. Gradeability in Crawler Gear	17.92%

Telematics/GPS Tracking

Telematics unit as standard fitment Service activation optional (Contact 1800 209 7979)
--



Call us on: 1800-209-7979 (Toll-free)

TATA MOTORS

For more information, please visit our website: www.tataprime.com. You can also contact our Sales Office: Tata Motors Limited, 20th Floor, Tower 2, One Indiabulls Centre, 841, Senapati Bapat Marg, Mumbai 400 013. Tel: 91 22 6658 6000; Fax: 91 22 6658 6010.

*Terms & Conditions apply.

The illustrations and photographs may show accessories and items of optional equipment which are not part of standard specifications. Due to printing processes, colours may vary slightly from those shown. All listed specifications are current and subject to change or upgrades without prior notice, in accordance with the Company's policy of continuous improvement.